



* 3 E R W 1 *

3	E	R	W	1
---	---	---	---	---

↑
請把電腦條碼貼在方格內
Please stick the barcode label in the box.

Education Bureau Territory-wide System Assessment 2023 Primary 3 English Language Reading & Writing

Instructions:

學生須知：

1. Stick barcode labels on pages 1, 3 and 5 in the spaces provided.
在第 1、3 及 5 頁的適當位置貼上電腦條碼。
2. There are 4 parts in this Question-Answer Booklet.
Answer all questions.
本卷共有 4 部分，全部題目均須作答。
3. Do not write in the margins.
請勿在框線以外書寫。
4. Time allowed is 30 minutes.
評估時限為 30 分鐘。
5. Write your School Code, Class and Class Number in the boxes below.
在下面的方格內填寫學校編號、班別及班號。

Instructions for answering questions:

作答說明：

Multiple Choice Questions – Blacken the circle next to the correct answer with an **HB pencil**. For example:

選擇題 – 選出正確的答案，並用 **HB 鉛筆** 把該選項的圓圈塗黑和塗滿，如：

- | | | | | |
|-------------------------------------|----|-------------------------------------|--|--------------------------|
| <input checked="" type="radio"/> A. | | <input checked="" type="radio"/> A. | | <input type="radio"/> B. |
| <input type="radio"/> B. | or | <input type="radio"/> C. | | <input type="radio"/> D. |
| <input type="radio"/> C. | 或 | <input type="radio"/> A. | | |
| <input type="radio"/> D. | | | | |

Other Questions – Write your answers in the spaces provided.

其他題目 – 在適當的位置內填寫答案

School Code
學校編號

P			
---	--	--	--

Class
班別

3	
---	--

Class No.
班號

--	--

↑
此格只許填寫一個大楷英文字母
Write one capital letter in this box.

請把電腦條碼貼在方格內
Please stick the barcode label in the box.

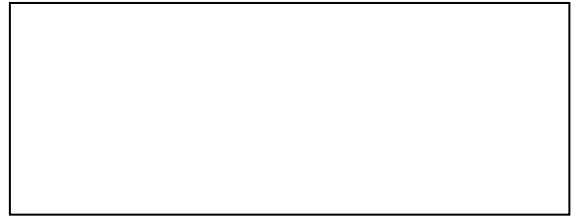

3. Mark can have _____ for lunch.

- A. toast with butter B. fried rice
 C. noodles with ham D. fish congee

4. Mark buys fried rice. He pays _____.

- A. \$25 B. \$28
 C. \$32 D. \$35

5. Mark buys two cups of lemon tea. He can get a _____ free.

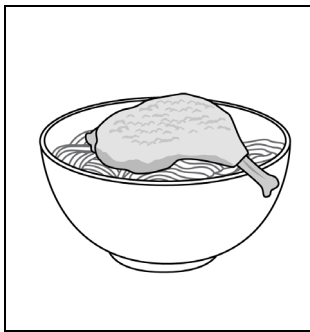

A.

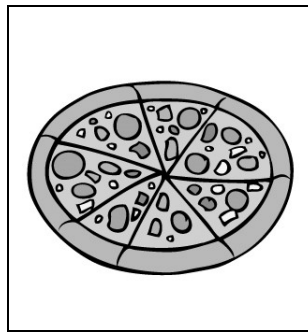

B.



C.

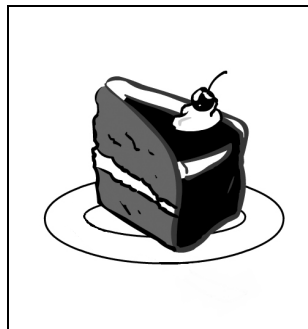

D.

Please do not write in the margin. 請勿在此書寫。

Please do not write in the margin. 請勿在此書寫。

請把電腦條碼貼在方格內
Please stick the barcode label in the box.

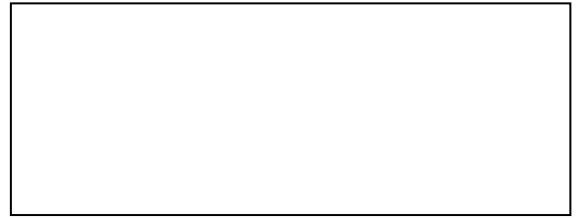

Please do not write in the margin. 請勿在此書寫。

4. Mark is not good at _____.

- A. Music B. PE
 C. Maths D. Art

5. Mark doesn't meet his friends. He is _____.

- A. poor B. unhappy
 C. angry D. healthy

6. What does Mark do in the park?

- 1) draw
2) sing
3) cycle
4) run

- A. 1 and 2
 B. 1 and 4
 C. 2 and 3
 D. 3 and 4

7. Read line 9. The word 'We' refers to _____.

- A. Mark and his friends B. Mark and his mum
 C. Mark and his schoolmates D. Mark and his teachers

Please do not write in the margin. 請勿在此書寫。

Part 3

Mark is reading a story.

Read the story.

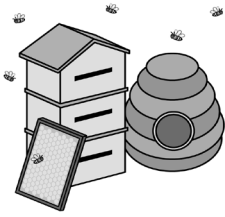

Tom and the Bees



1

Tom loves birds, fish and butterflies but he is afraid of bees.

One school holiday, he visits Aunt Mary's farm. It is a beautiful, quiet place. Aunt Mary shows Tom some wooden boxes. Tom sees many bees in the boxes and screams loudly. Everyone on the farm can hear him.

5

Aunt Mary says, "Bees are helpful. They make honey in the boxes." She gives Tom a spoon of honey. "It tastes sweet," she says. "It's healthy too." Aunt Mary gives him a jar of honey and a book about bees to take home.

10

Now Tom knows bees are good for the Earth because they help plants to grow. They are our friends. He sees the bees on the farm every weekend and he loves them.

Please do not write in the margin. 請勿在此書寫。

Please do not write in the margin. 請勿在此書寫。

Choose the best answer by blackening the circle.

1. At the beginning of the story, Tom is afraid of _____.

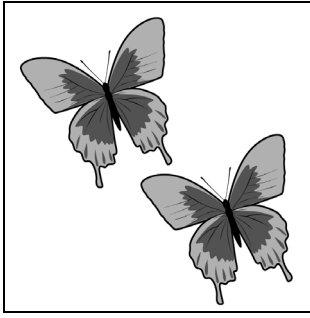

A.

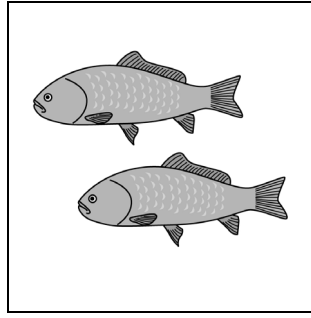

B.

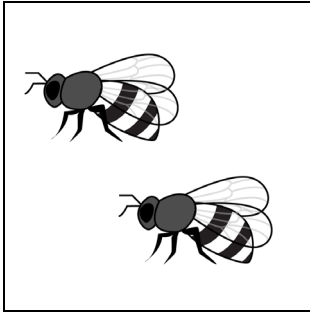

C.

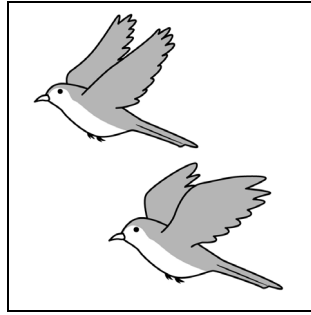

D.

2. One school holiday, Tom visits a _____.

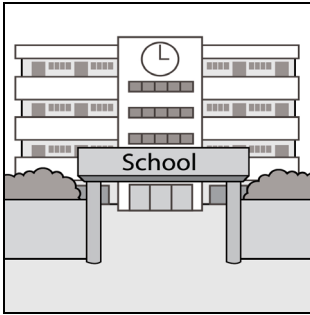

A.

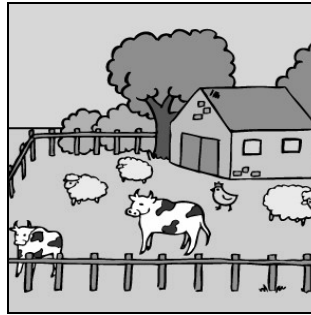

B.

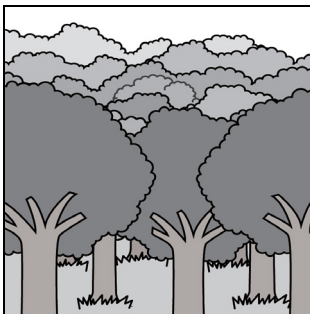

C.

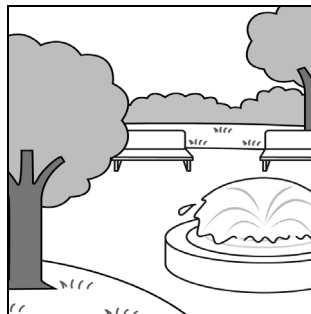

D.

3. Read line 6. The word 'screams' means _____.

- A. visits
- B. tastes
- C. shows
- D. shouts

4. Aunt Mary thinks honey is _____.

- 1) beautiful
- 2) healthy
- 3) unhealthy
- 4) sweet

- A. 1 and 2
- B. 2 and 4
- C. 3 and 4
- D. 1 and 3

5. Aunt Mary gives Tom a _____ of honey to take home.

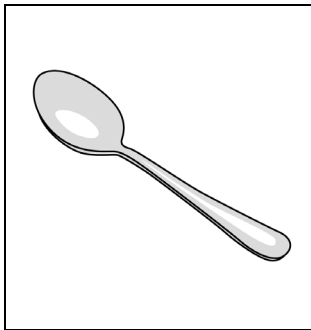

A.

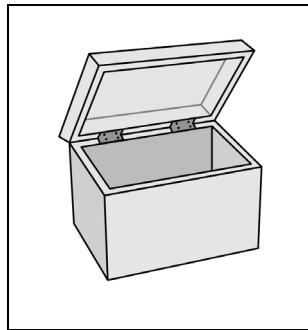

B.

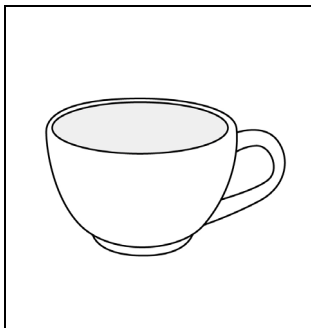

C.

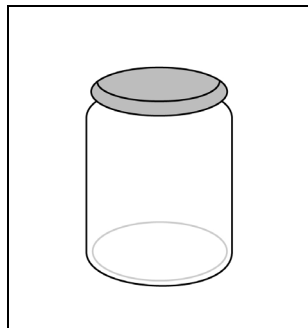

D.

6. Read lines 12 – 14. Why are bees good for the Earth?

- A. They help plants to grow.
- B. They live on a farm.
- C. They are birds' friends.
- D. They are lovely.

7. At the end of the story, Tom visits the farm _____.

- A. at weekends
- B. on school holidays
- C. when he is not afraid
- D. when he needs honey

8. Read line 14. The word 'them' refers to _____.

- A. the plants
- B. the boxes
- C. the bees
- D. Aunt Mary and Tom

Part 4

You are writing a story about Susan and her brother John.

Look at the pictures and write the story in about 30 words.

- ◆ You may use the words in the boxes to help you.
- ◆ What happens in the end? Finish the story.



sleep / homework



draw / naughty



wake up

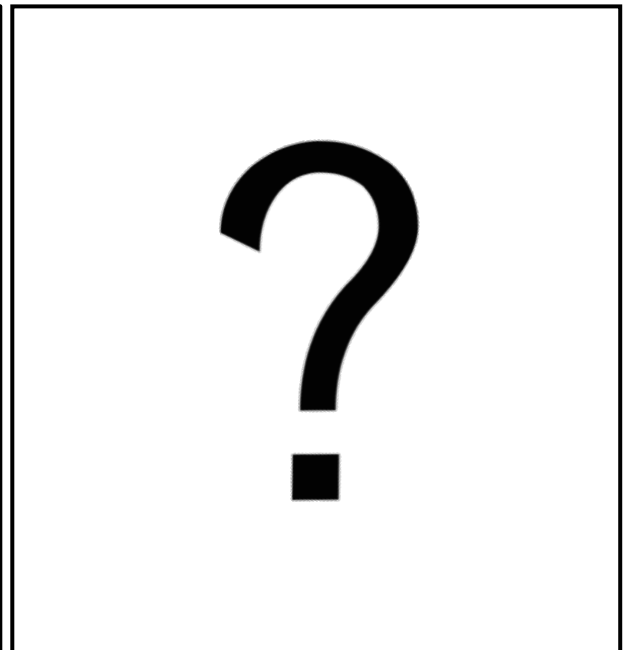

Please do not write in the margin. 請勿在此書寫。

Please do not write in the margin. 請勿在此書寫。

