



* 6 M E 3 *

6	M	E	3
---	---	---	---



請把電腦條碼貼在方格內
Please stick the barcode label in the box

Education Bureau

Territory-wide System Assessment 2026[◆]

Primary 6

Mathematics

Instructions:

1. Stick barcode labels on pages 1, 3, 5, 7 and 9 in the spaces provided.
2. There are 39 questions in this test. Answer all questions.
3. Time allowed is 50 minutes.
4. Write your answers in this Question-Answer Booklet.
5. Do not write in the margins.
6. Use of calculators is not allowed.
7. Do your rough work on the rough work sheet provided.
8. Write your School Code, Class and Class Number in the boxes below.

Instructions for answering questions:

(a) Multiple choice questions – Blacken the circle next to the correct answer with an **HB pencil**.

For example:

- A
- B
- C
- D

(b) Questions in which you are asked to “Show your working” – Write your mathematical expressions, answers and statements/conclusions in the spaces provided. There is **NO** need to show your rough work.

(c) Other types of questions – Answer as required in the spaces provided.

School Code
學校編號

P			
---	--	--	--

Class
班別

6	
---	--

Class No.
班號

--	--



此格只許填寫一個大楷英文字母
Write one **capital letter** in this box

◆ 2026 年小六全港性系統評估暫停舉行。此評估是學校以自願形式參與，而非全體小六學生參與的全港性系統評估。
The 2026 P6 TSA has been suspended. Participation in this assessment is on a voluntary basis. As a result, this is a TSA in which not all P6 students will participate.

Please do not write in the margin.

1. Which of the following numbers has the digit '6' in its millions place?

- A. 24 769 000
- B. 71 385 600
- C. 564 012 000
- D. 846 570 000

2. Which of the following numbers are prime numbers?
(Circle all the answers)

7

12

23

35

3. List all the factors of 26.

Answer: _____

4. Which of the following numbers are common multiples of 6 and 15?

(Circle all the answers)

1

3

45

60

90

Please do not write in the margin.

請把電腦條碼貼在方格內
Please stick the barcode label in the box



Please do not write in the margin.

5. Which of the following numbers is the Highest Common Factor (H.C.F.) of 28 and 42?

- A. 84
- B. 14
- C. 7
- D. 6

6. (a) Convert $\frac{92}{9}$ to a mixed number.

Answer:

(b) Fill in the box with the correct number.

$$\frac{2}{13} = \frac{8}{\boxed{}}$$

Please do not write in the margin.

Please do not write in the margin.

7.

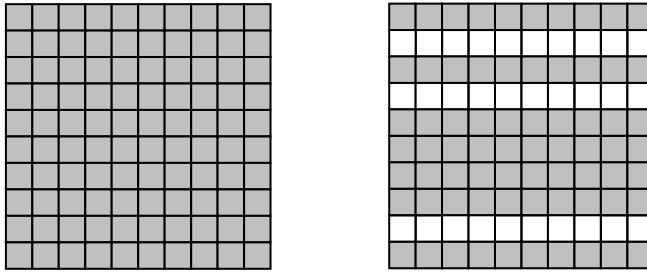

There are two large squares in the diagram above. Each large square stands for 1.

Use a decimal to represent the shaded parts in the diagram.

- A. 1.07
- B. 1.7
- C. 170%
- D. 170

8. Convert 0.72 to a fraction in the lowest terms.

Answer:

Please do not write in the margin.

請把電腦條碼貼在方格內
Please stick the barcode label in the box

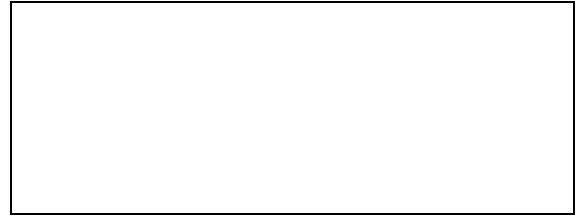

Please do not write in the margin.

9. Arrange the following numbers from the largest to the smallest.

80.9 , 8.413 , 80.27

Answer: _____ , _____ , _____
(Largest) (Smallest)

10. (a) Convert $\frac{1}{200}$ to a percentage.

Answer: _____ %

- (b) Convert 13% to a decimal.

Answer: _____

Please do not write in the margin.

Please do not write in the margin.

11. $36 + 324 \div 3 =$

- A. 54
- B. 108
- C. 120
- D. 144

12. $\frac{2}{5} \times 2\frac{1}{12} \div \frac{4}{9} =$

13. $14 \div \left(\frac{1}{9} + \frac{7}{9} \right) =$

14. $7.24 + 3.6 - 1.08 =$ _____

15. $5.8 \div 0.7 =$ _____

(Round the answer to two decimal places)

Please do not write in the margin.

請把電腦條碼貼在方格內
Please stick the barcode label in the box

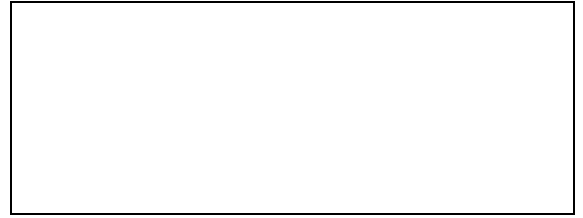

Please do not write in the margin.

16. In a party, 6A students ate $4\frac{1}{12}$ pizzas.

6B students ate $3\frac{5}{6}$ pizzas. Students of 6A and 6B

ate pizza(s) altogether.

17.

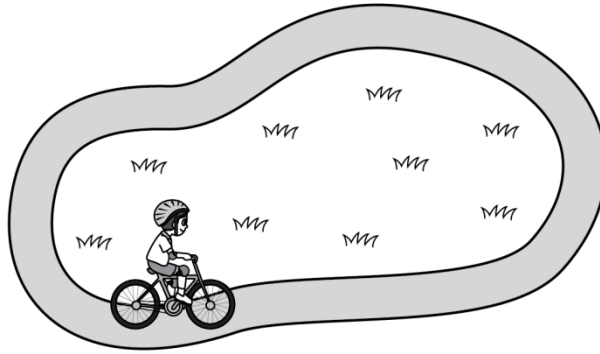

One lap around a cycling track is $1\frac{1}{2}$ km. Yanny rode a bike along the track for 6 km. She made lap(s).

18. Betty is an athlete. She runs 1.6 hours in the morning and 1.5 hours in the afternoon every day.

In total she runs _____ hour(s) in one week.

Please do not write in the margin.

Please do not write in the margin.

19. The weight of Sam is 40 kg. Gigi is heavier than Sam by 10%. What is the weight of Gigi in kg?
(Show your working)



Please do not write in the margin.

20. A table tennis match lasted for 30 minutes and finished at 3:25 p.m. In '24-hour time', the starting time was _____ : _____ .

請把電腦條碼貼在方格內
Please stick the barcode label in the box

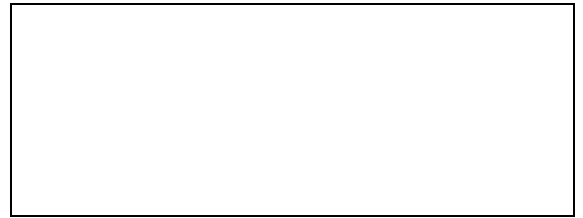

21.

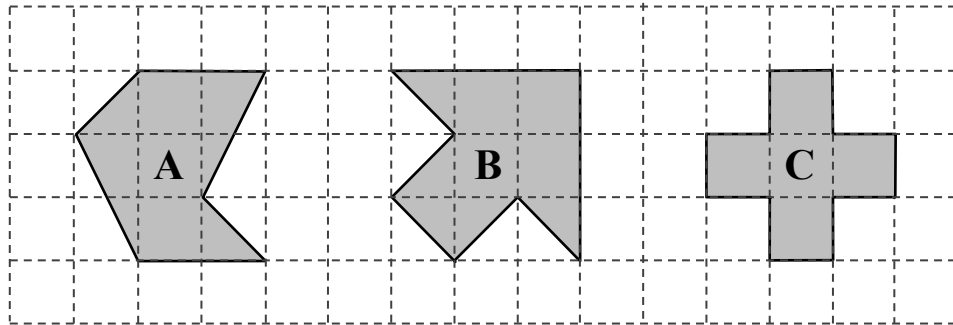

Compare the areas of the 2-D shapes **A**, **B** and **C** above.
Arrange them from the smallest to the largest. Write all the letters for the answers.

Answer: _____ , _____ , _____
(Smallest) (Largest)

22.

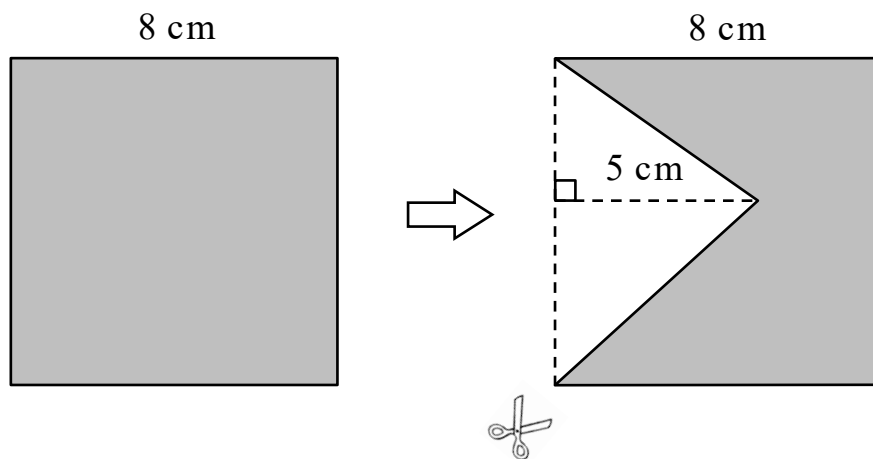

Cut a triangle from a piece of square cardboard,
the area of the remaining part is _____ cm^2 .

Please do not write in the margin.

Please do not write in the margin.

23. In the figure below, points **B** and **C** are the centres of the large circle and the small circle respectively. Points **A** and **C** are on the circumference of the large circle. Point **D** is on the circumference of the small circle. Points **A**, **B**, **C** and **D** are on the same straight line.

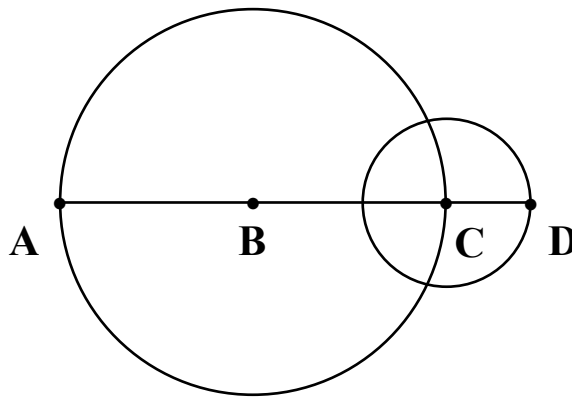

- (a) * **AB** / **AC** / **AD** is the diameter of the large circle. (*Circle the answer)
- (b) **CD** is 3 cm long. The circumference of the small circle is _____ cm. (Take π as 3.14)

24.

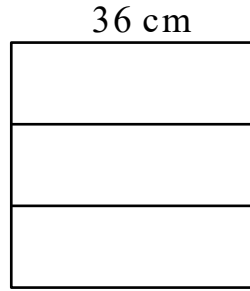

The square above is made up of 3 equal rectangles.

The perimeter of each rectangle is _____ cm.

25

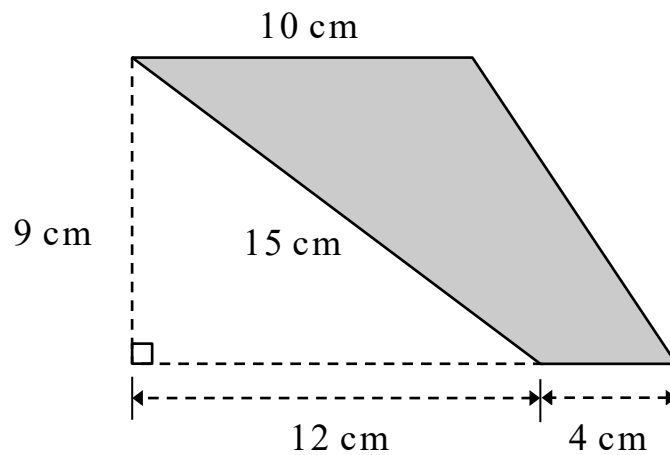

What is the area of the trapezium above?

- A. 63 cm^2
- B. 105 cm^2
- C. 117 cm^2
- D. 126 cm^2

26. A cable car travels at an average speed of 15 kilometres per hour. It travels 18 kilometres in _____ hour(s).

Please do not write in the margin.

Please do not write in the margin.

Please do not write in the margin.

27.

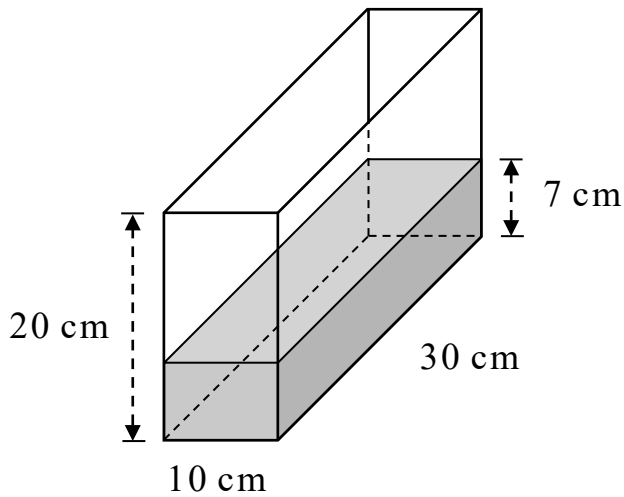

The diagram above is a cuboid container, it contains some water.

- (a) The volume of the water is _____ cm^3 .
- (b) The capacity of the container is _____ L.

28.

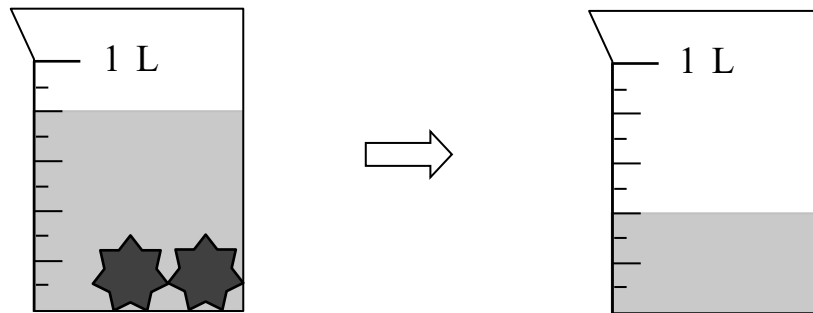

The volume of each  is _____ cm^3 .

Please do not write in the margin.

Please do not write in the margin.

29. Measure the following angles with a protractor. Arrange them from the smallest to the largest. Write all the letters for the answers.

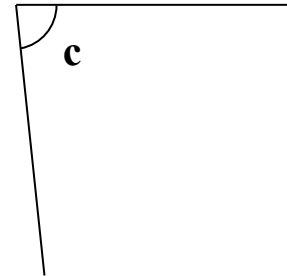
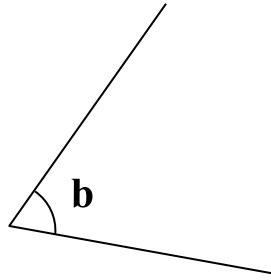
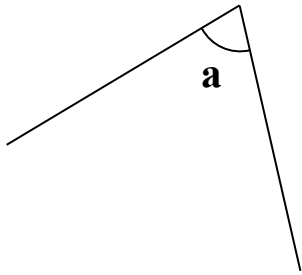

Answer: \angle _____ , \angle _____ , \angle _____
(Smallest) (Largest)

- 30.

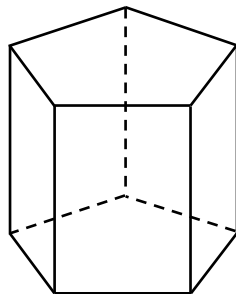

The figure above is a 3-D shape.

It has _____ edge(s).

Please do not write in the margin.

Please do not write in the margin.

31. Which of the following 2-D shapes has only one pair of opposite sides parallel?

- A. Parallelogram
- B. Rhombus
- C. Trapezium
- D. Isosceles triangle

32. Which of the following diagrams can indicate all the axes of symmetry of the shape with a dotted line/ dotted lines?

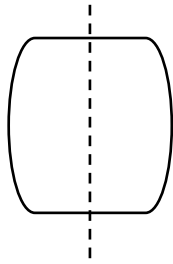

A.

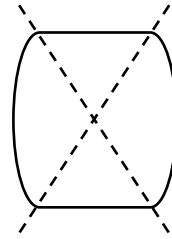

B.

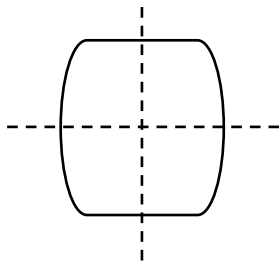

C.

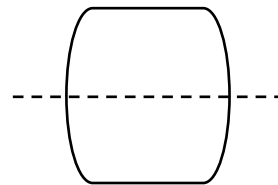

D.

Please do not write in the margin.

Please do not write in the margin.

33. The map of an art museum is shown below.

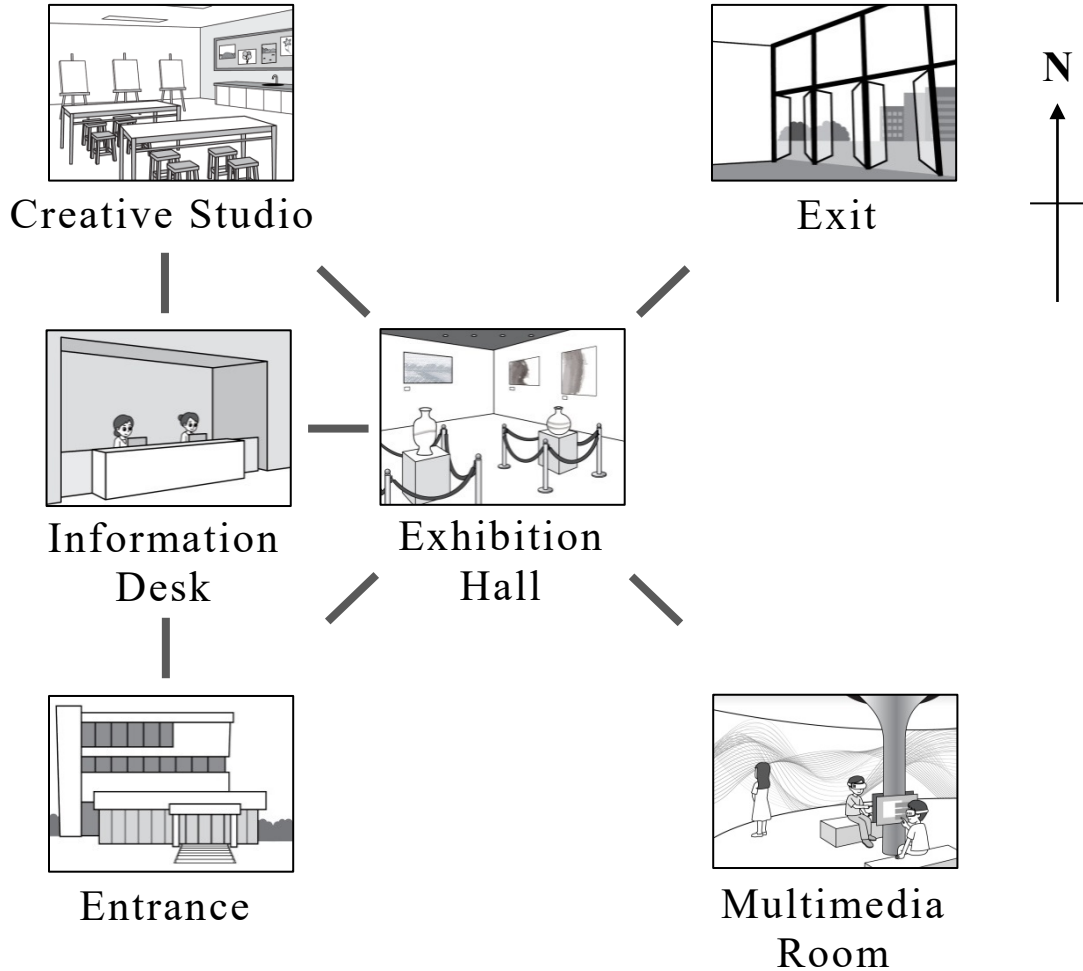

Please do not write in the margin.

(a) To the south of Information Desk

is _____ .

(b) Starting from Multimedia Room, Ms Chan

goes _____ to reach Exhibition Hall. Then
(direction)

she turns north-east to reach _____ .

34. Find the average of the five numbers below.

21 , 15 , 17 , 19 , 8

Answer: The average is _____ .

35. Each box of cakes contains x pieces. Johnny bought 6 boxes of cakes. He ate 5 pieces. How many pieces of cakes are left?

- A. $6x - 5$
 B. $x - 5$
 C. $(x - 5) \times 6$
 D. $x - 30$

36. $\frac{a}{6} - 5 = 7$

$a =$

Please do not write in the margin.

37. Jason bought one ruler and some pencils.
He paid 12.5 dollars in total. Each ruler costs 4.5 dollars.
Each pencil costs 2 dollars. Find the number of pencils
Jason bought by *the method of solving an equation*.
(Show your working)

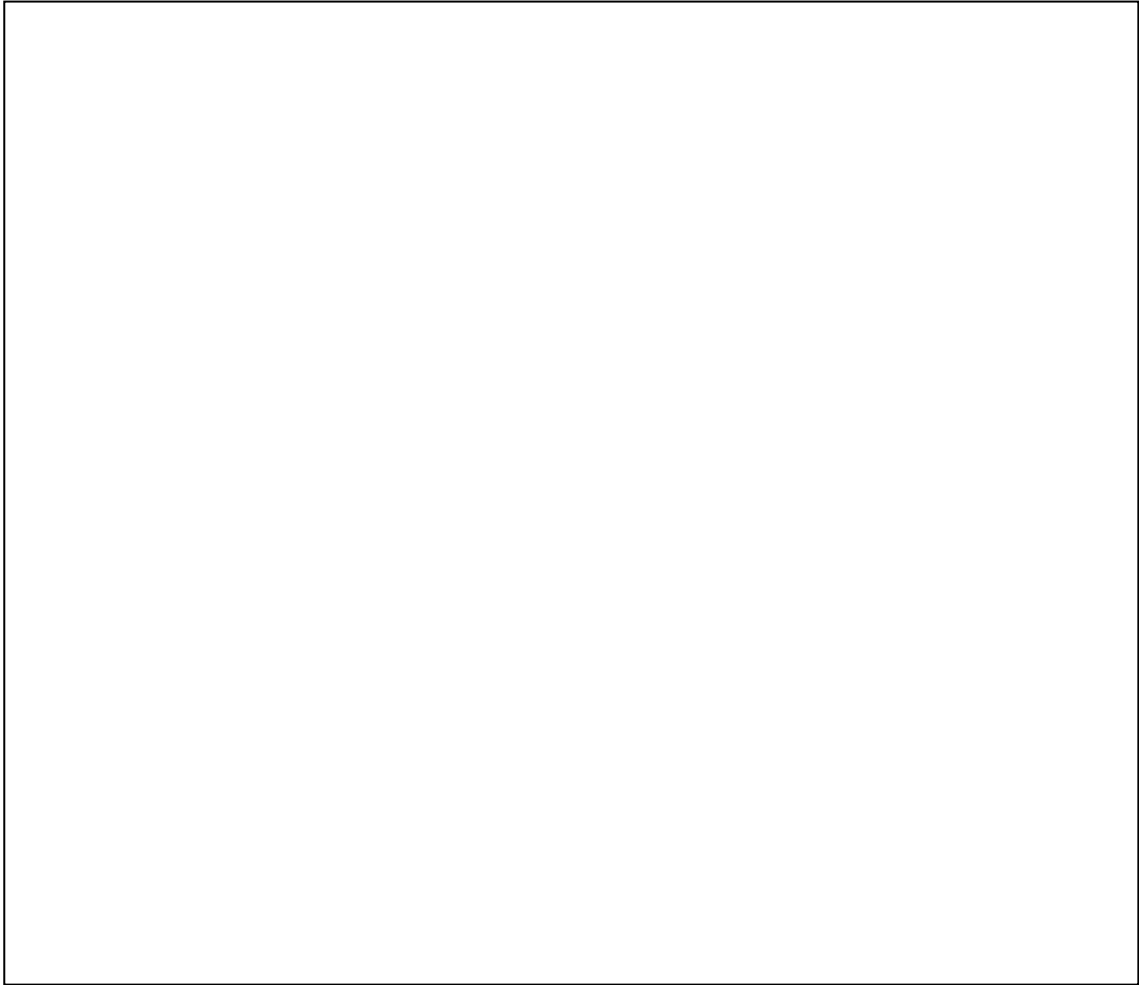

Please do not write in the margin.

Please do not write in the margin.

38. The following bar chart shows the recycling amount for different types of items at a recycling station last week.

Recycling Amount for Different Types of Items at a Recycling Station Last Week

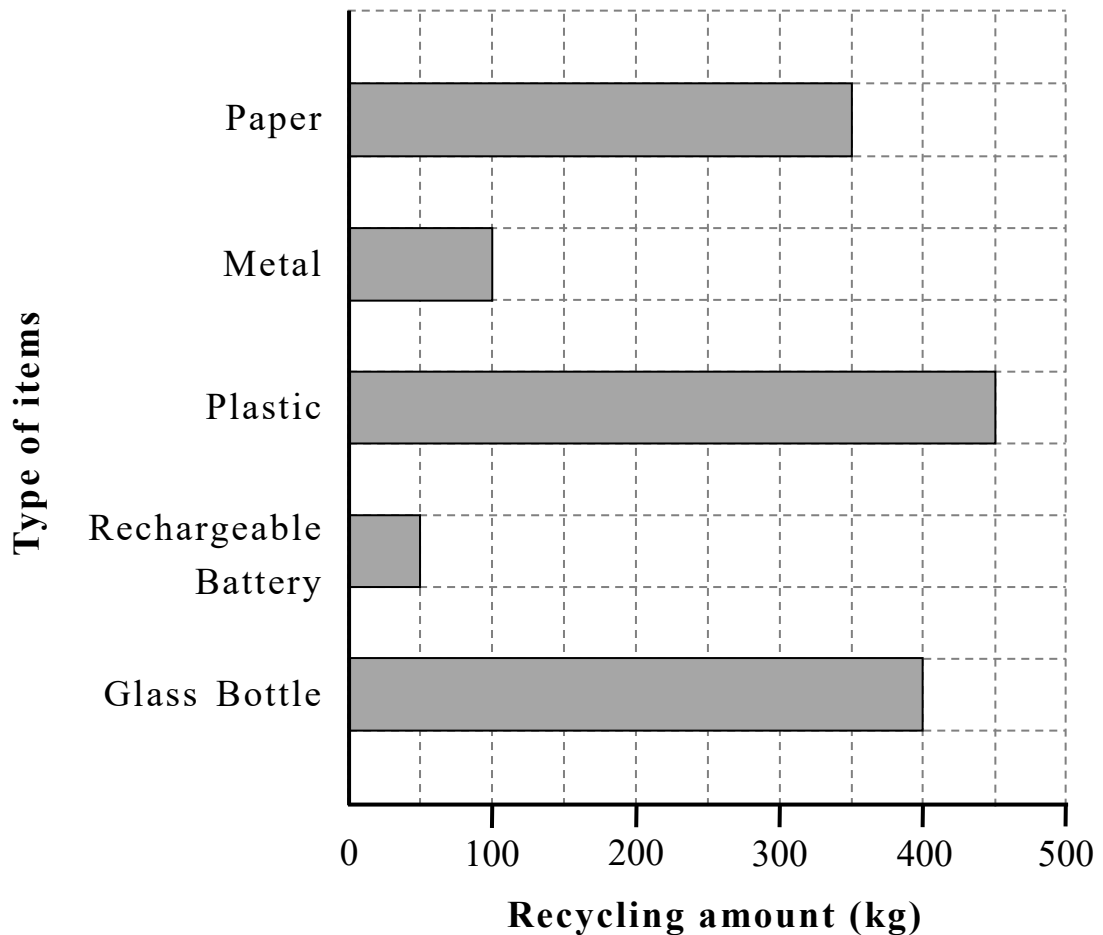

Please do not write in the margin.

- (a) The recycling amount of _____ was the largest. _____ kg were recycled.
- (b) What fraction of the recycling amount of glass bottles was the recycling amount of metals?

Answer: The recycling amount of metals was

of that of glass bottles.

Please do not write in the margin.

39. The table below shows the number of Tom's swimming days in the past five months.

Month	March	April	May	June	July
Number of swimming days	15	23	20	25	12

According to the information above, use a pencil to complete the following broken line graph. Give it a title and add the scales.

(Title)

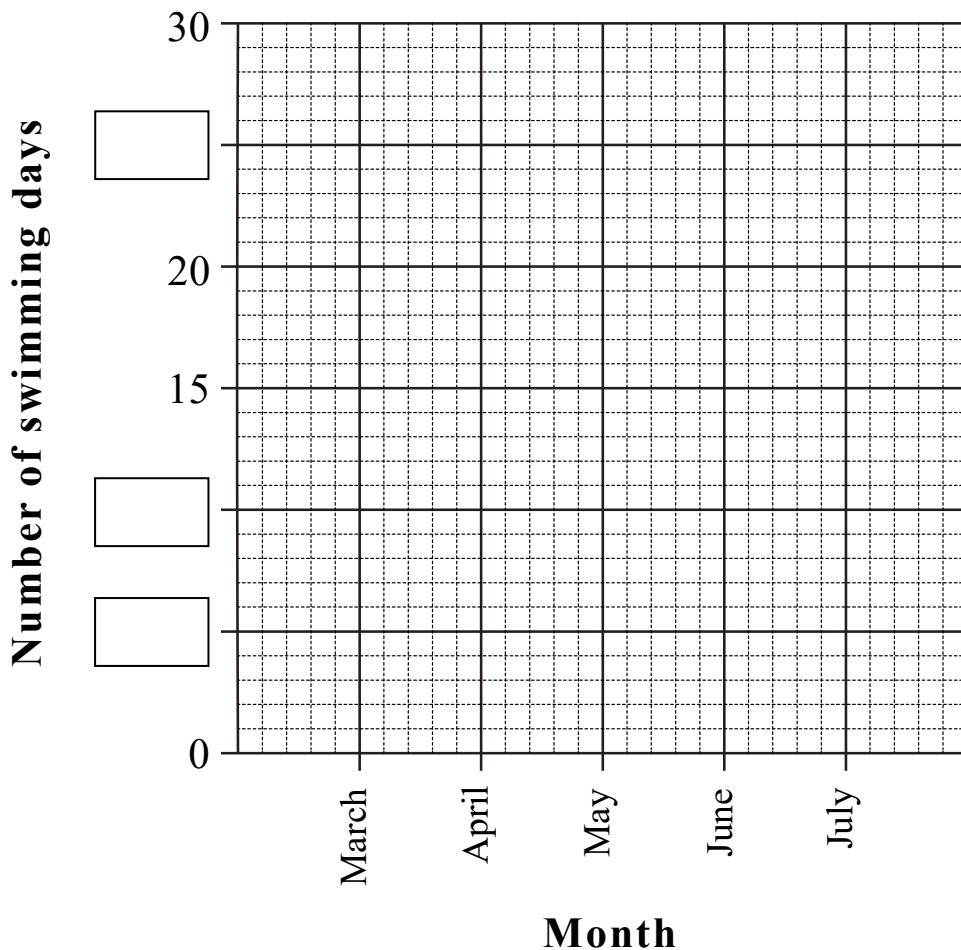

— END OF PAPER —

Please do not write in the margin.

